

JTF2 PLUS

TrayStak® Feeder

LOAD OR UNLOAD STACKS FULL OF PRODUCT WITHOUT INTERRUPTING PRODUCTION

The **QUASYS JTF2 PLUS** is the automation solution for JEDEC Tray feeding. Load and unload stacks of up to 20 thick or 30 thin JEDEC standard trays without interrupting the assembly equipment.

- ✦ Dramatically increase throughput by automatically delivering trays non-stop
- ✦ Low cost of ownership
- ✦ Tray exchange in less than 6 seconds
- ✦ Compact Footprint – occupies less than 162 mm of feeder rail space
- ✦ Microprocessor controlled
- ✦ CE approved
- ✦ Large customer base



EASILY INTEGRATE WITH YOUR MACHINE:

SMT Assembly Equipment
Singulation Equipment
Device Programmers
Test Handlers
Die Bonders
Inspection Equipment
Custom Automation

PLUS FEATURES

- ✦ Highest feeding stability
- ✦ Closed loop control elevator/conveyor drive using encoded maxon motor
- ✦ Added interfaces RS485, Ethernet UDP and TCP/IP, USB^{Virtual COM}
- ✦ Upgrade kits available for existing Feeders
- ✦ Applicable to all **Quasys** Feeders
- ✦ No potentiometers
- ✦ Reverse compatible
- ✦ Footprint remains
- ✦ Swiss Made

JTF2 Plus

TrayStak® Feeder

TECHNICAL SPECIFICATION

Capacity

20 thick or 30 thin JEDEC trays
(standards 95-1 & IEC 60286-5)
max. stack weight 9 kg, optional 18 kg
max. tray weight 800 g

Speed

Tray exchange 5.5 to 7 sec, depending on applications

Position Accuracy

Edge of tray repeatable to 0.05 mm

Flexibility

Microprocessor controlled, adjustable conveyor speed,
switch selectable thick/thin, tray changeover

Standards Compliance

SEMI S2 & S8, NFPA 70 & 79, CE

Electrical

24 VDC \pm 10 %, 2 amps (peak), 1.0 [A] continuous

Communication Signals

dIO, RS232, RS485, Ethernet UDP and
TCP/IP, Vcom, SMEMA

Pneumatic

5–6 Bar

Weight

22.7 kg (50 lbs)

Environment

10–35°C / 10–90 % R.H.

Feeder Width: 162 mm
Feeder Height: 588 mm
Feeder Length: 1015 mm

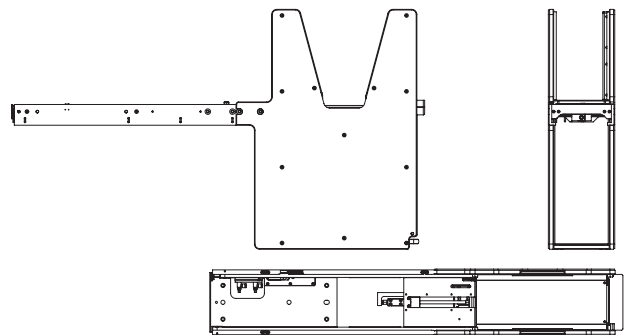

QUASYS AG

Rothusstrasse 5a
CH-6331 Hünenberg
Switzerland
sales@quasys.ch

ASIA

Auleetech Singapore
Oliver Ackermann
+65 6247 5157
oliver.ackermann@
auleetech.com

USA EAST

trayfeeders.com
Concord NH
Neil Burrtt
+1 603 227 5240
info@trayfeeders.com

USA WEST

Bentleadtools
San Jose CA
Bob Santora
+1 (408) 592 5259
bob@bentleadtools.com